



MULTIPATHWAY  
WORKSHOP

# Multi-pathway Workshop

2024年5月28日

トヨタ自動車株式会社

CTO 中嶋 裕樹

Hiroki Nakajima, Chief Technology Officer  
Toyota Motor Corporation

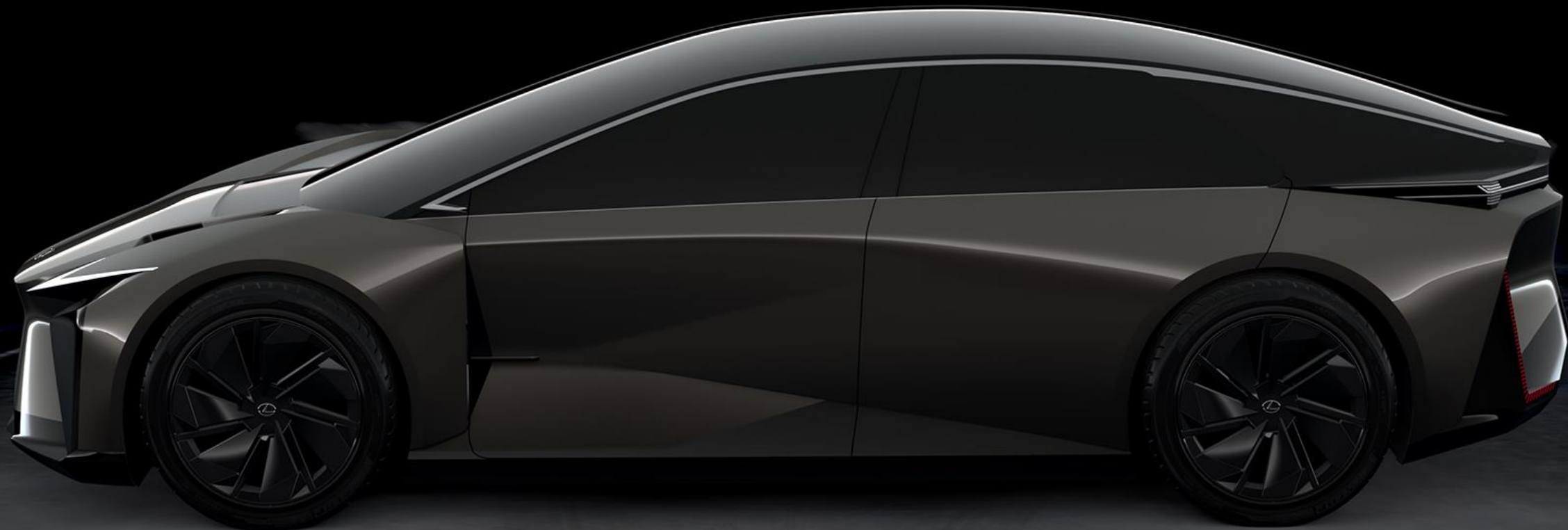

クルマ屋が創るBEV  
BEVs created by carmaker

# 水素エンジン Hydrogen Engine



# カーボンニュートラル Carbon Neutrality



# 敵は炭素

The only enemy is carbon!



# 新エンジン概要 (体格) 1.5L NA

New Engine overview (size) 1.5L NA

## 既存1.5L NA

Current 1.5 NA

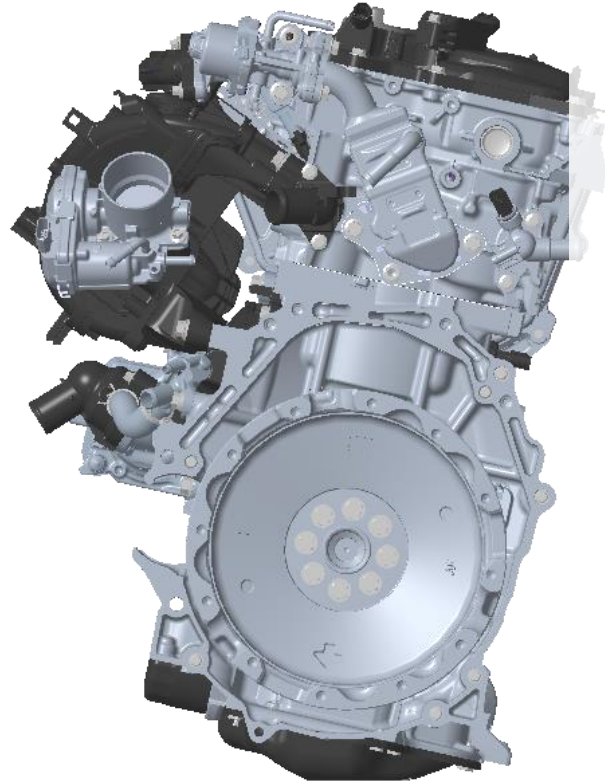

## 新1.5L NA

New 1.5 NA

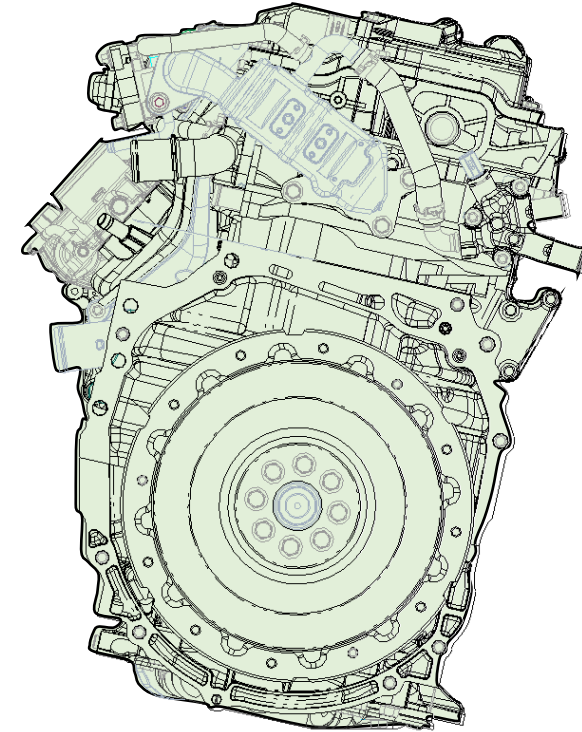

体積：10%低減

Volume : 10% reduction

全高：10%低減

Height : 10% reduction

NA: Naturally Aspirated

# 新エンジン概要 (性能) 1.5L NA

New Engine overview (Performance) 1.5L NA

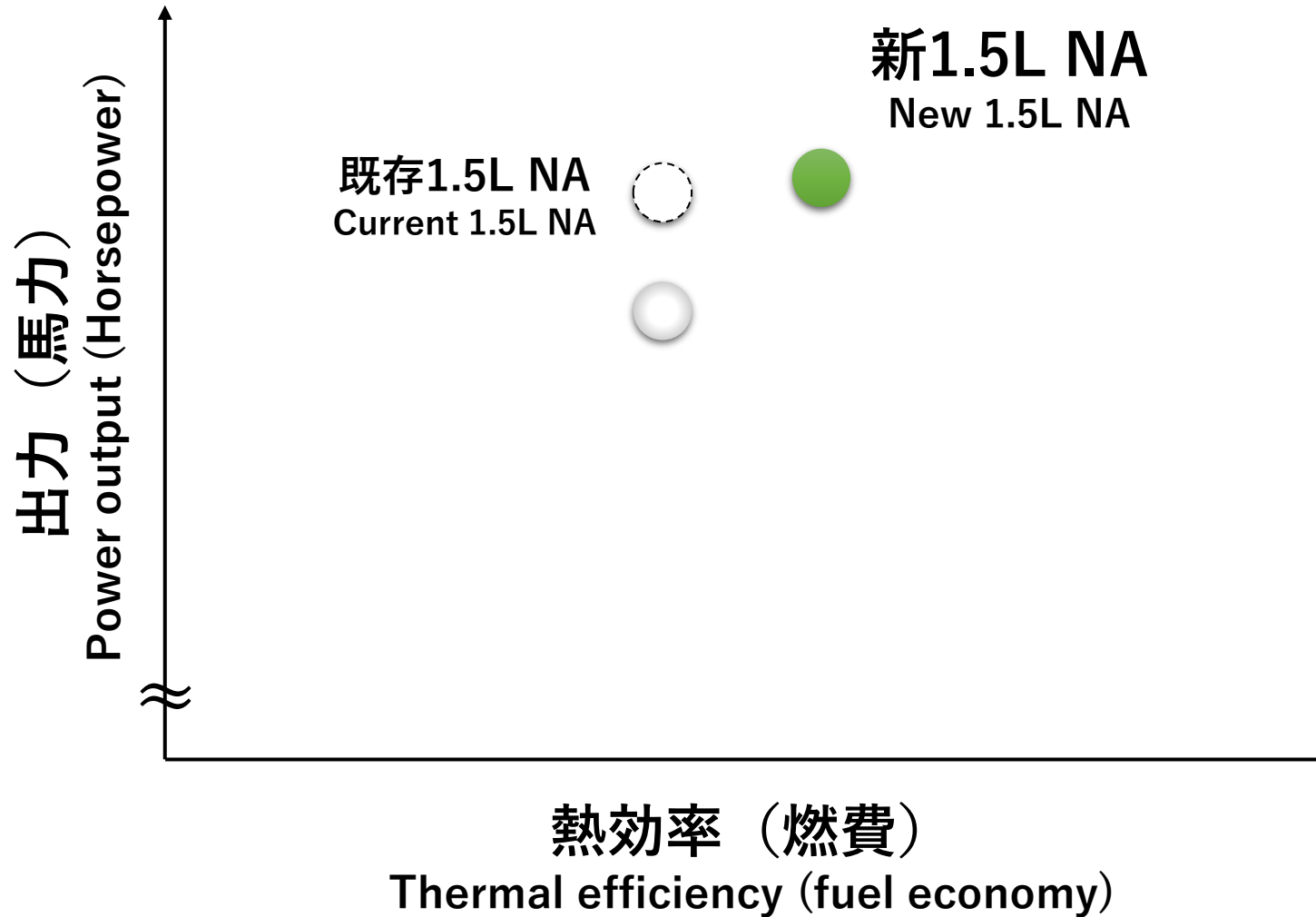



# 新エンジン概要 (性能) 1.5L 過給

New Engine overview (Performance) 1.5L Turbo

既存2.5L NA  
Current 2.5 NA

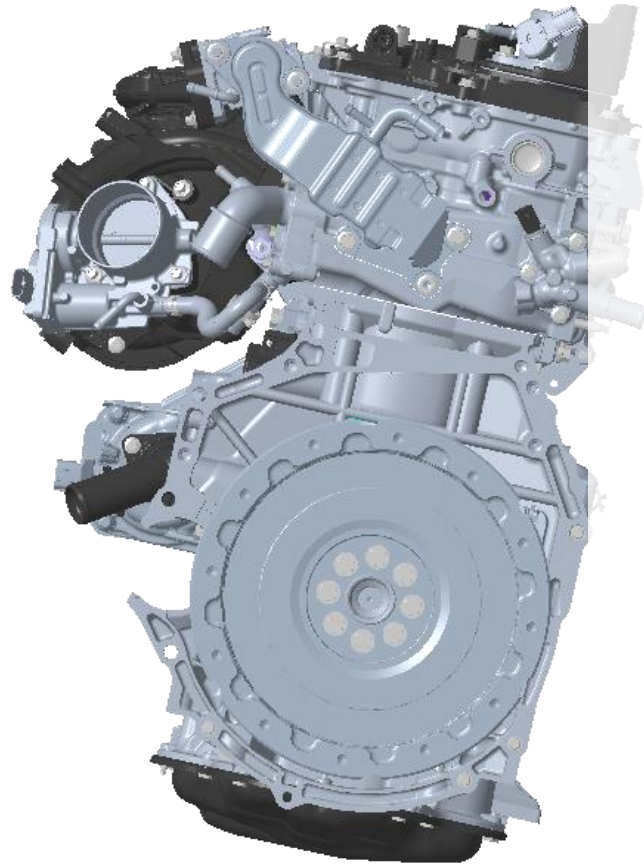

体積 : 20%低減  
Volume : 20% reduction

新1.5L 過給  
New 1.5 Turbo

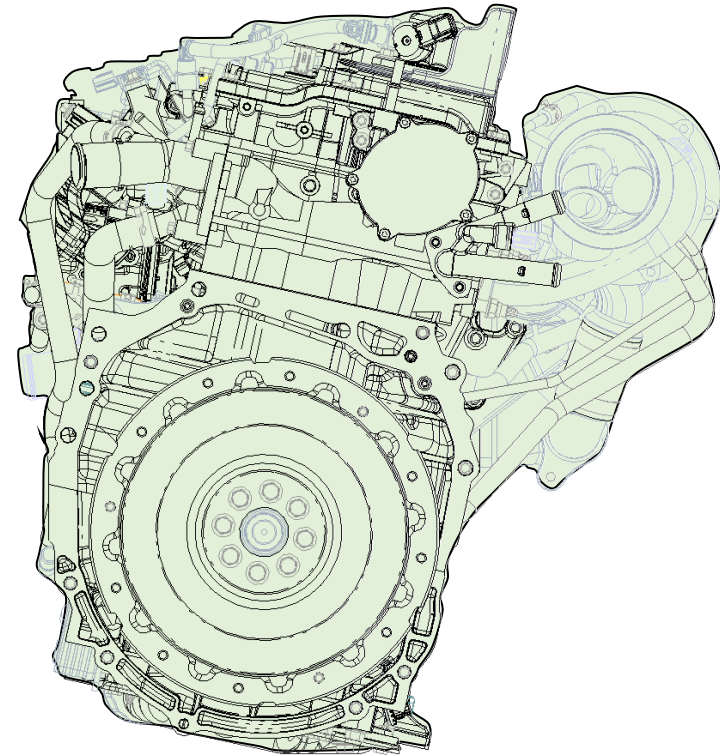

全高 : 15%低減  
Height : 15% reduction

# 新エンジン概要 (性能) 1.5L 過給

New Engine overview (Performance) 1.5L Turbo

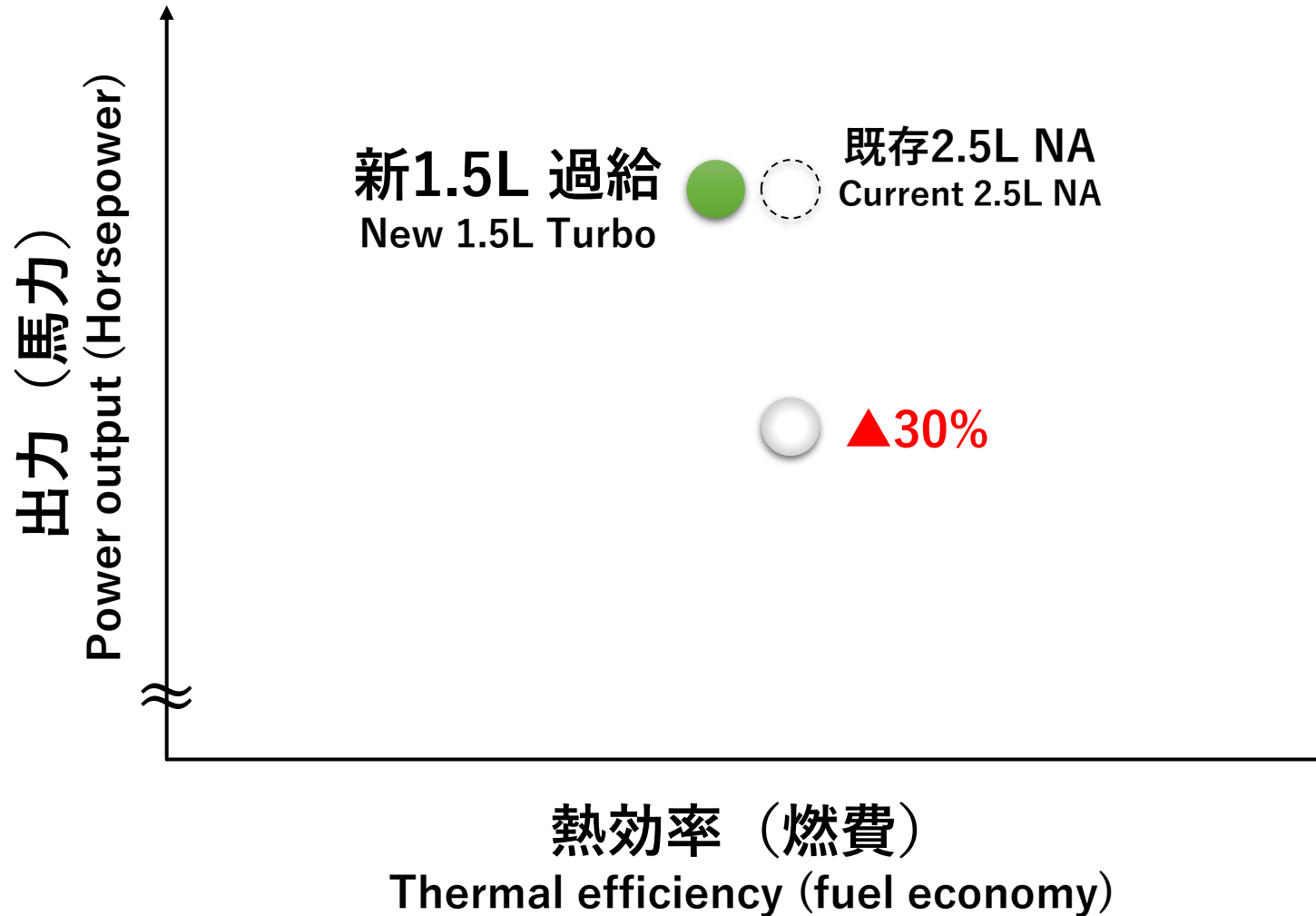

# 新エンジン概要 (体格) **2.0L 過給**

New Engine overview (Size) **2.0L Turbo**

既存**2.4L 過給**

Current 2.4 Turbo

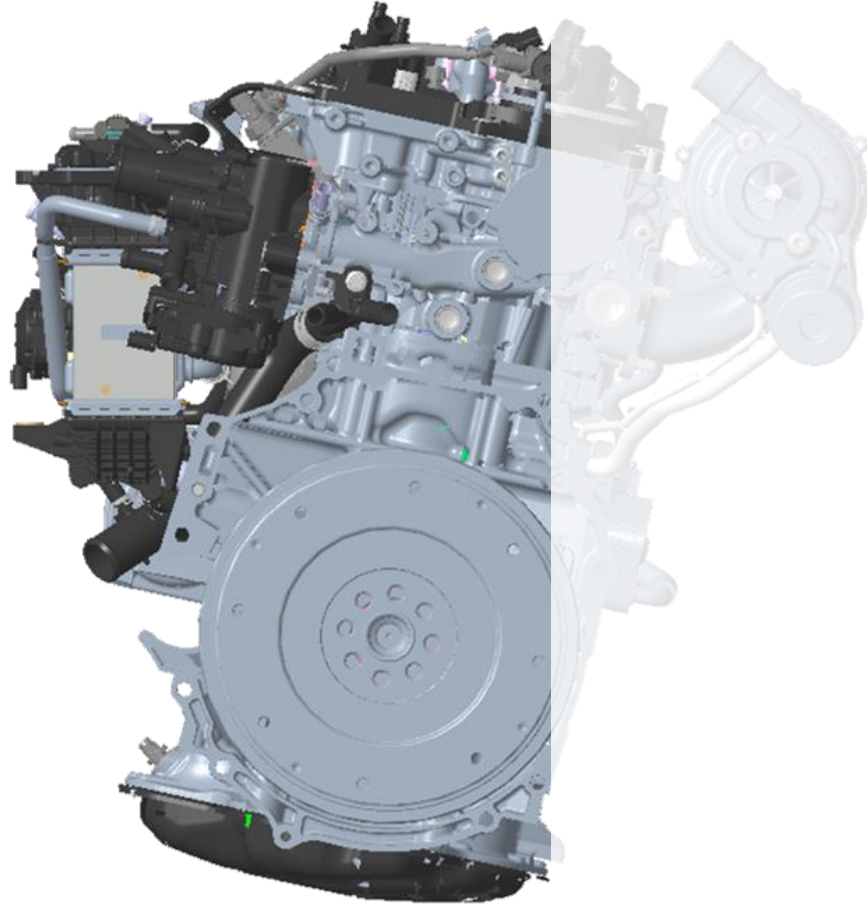

体積：**10%低減**

Volume : **10% reduction**

新**2.0L 過給**

New 2.0 Turbo

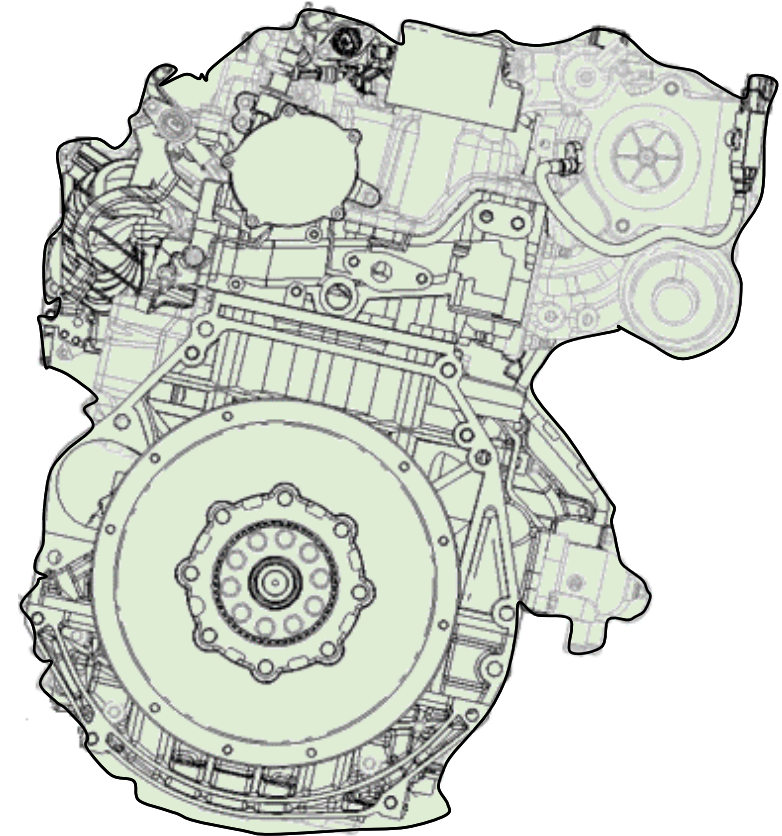

全高：**10%低減**

Height : **10% reduction**

# 新エンジン概要 (性能) 2.0L 過給

## New Engine overview (Performance) 2.0L Turbo

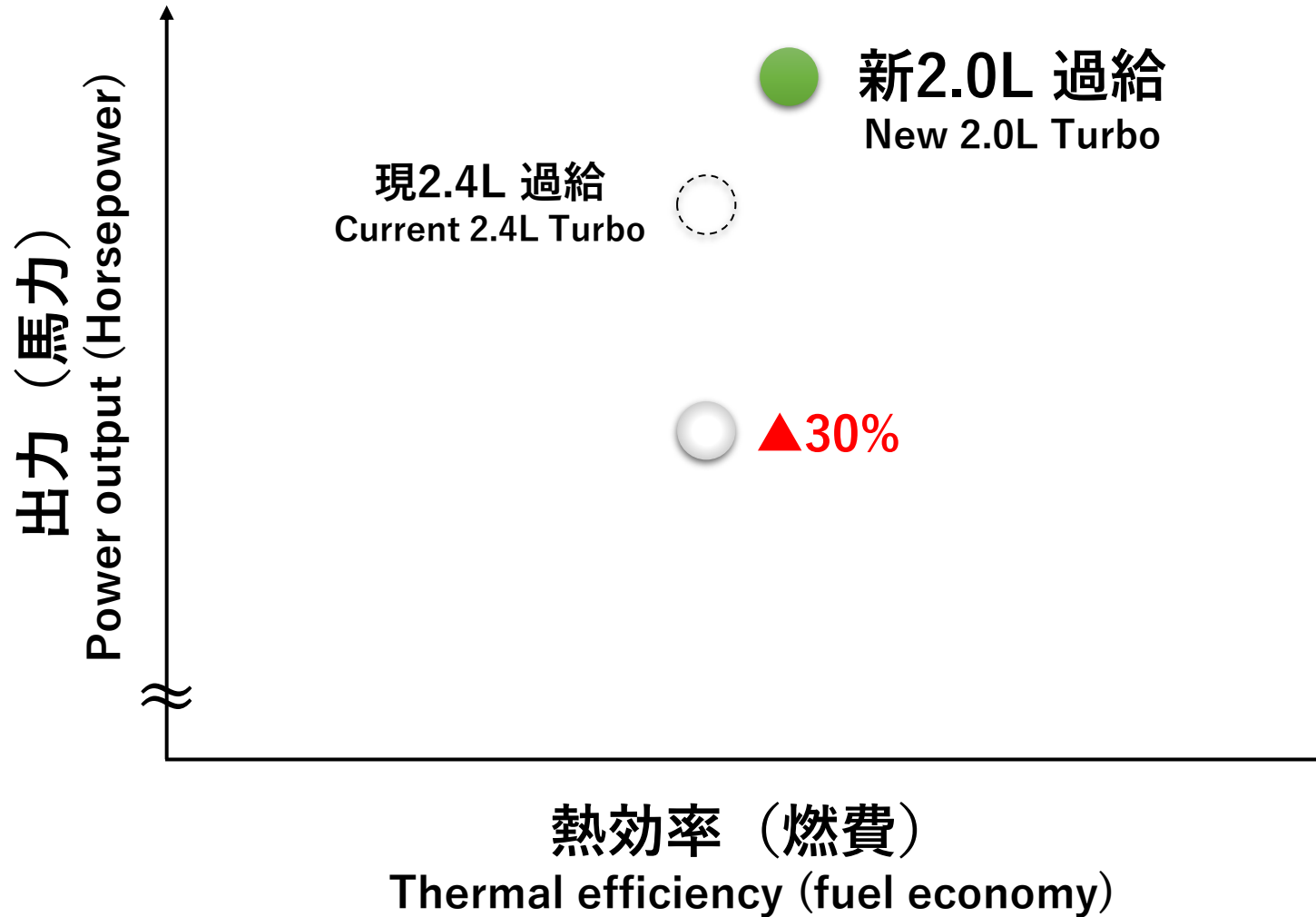

# 電動化時代のエンジン New Engine for electrification

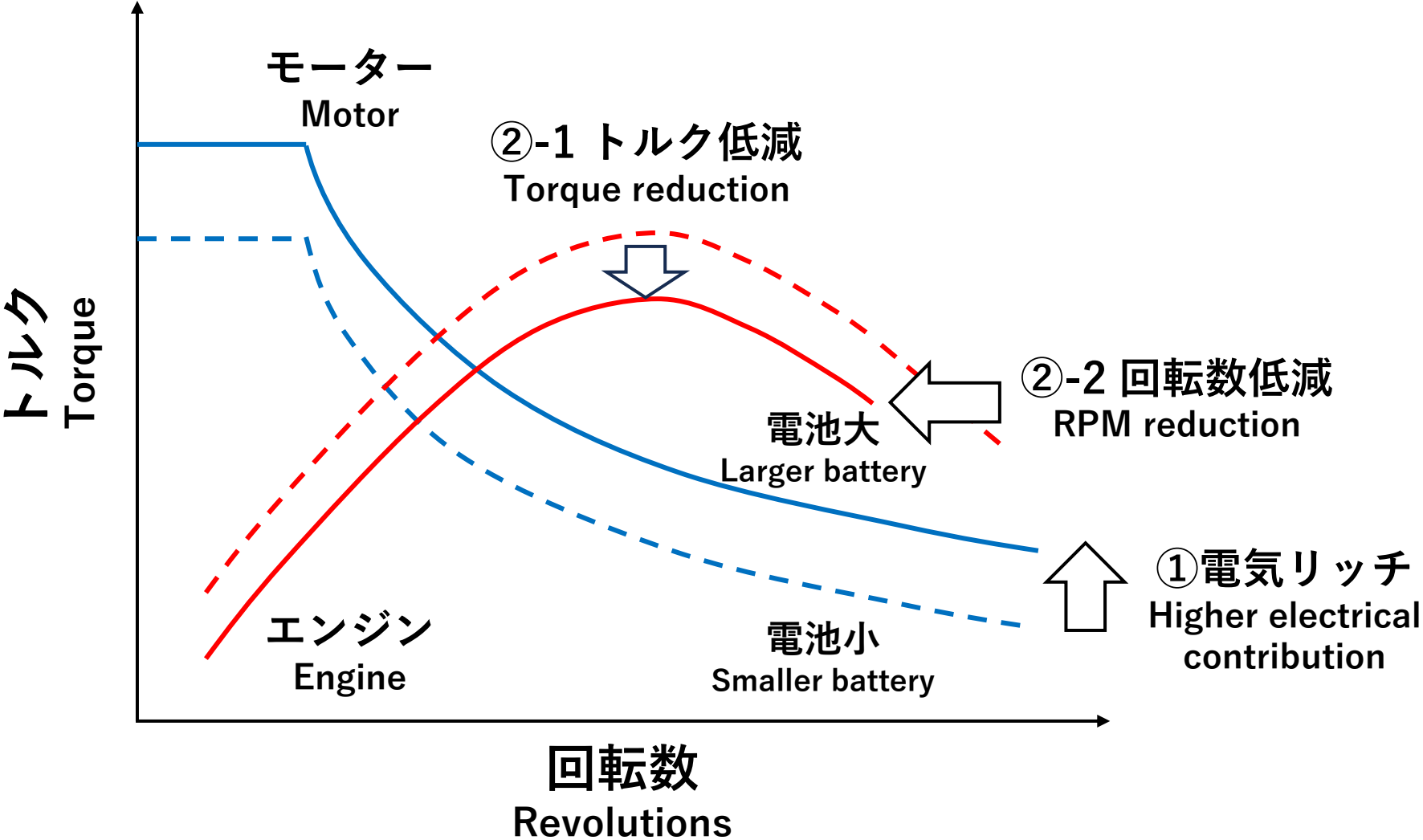

# 電動化時代のエンジン

New Engine for electrification



**クルマの未来を変えていこう！  
Let's change the future of cars!**



MULTIPATHWAY  
WORKSHOP